

(19)



Office de la propriété
intellectuelle
du Canada

Un organisme
d'Industrie Canada

Canadian
Intellectual Property
Office

An Agency of
Industry Canada

(11) Publication number:

CA 86749

(13) Document type:

A

(43) Publication date:

26.04.1904

(51) Int. Cl:

(12)

(21) Application number: **86749D**

(71) Applicant: **DODGE EDGAR C (US)**

(22) Date of filing: **11.12.1903**

(72) Inventor: **DODGE EDGAR C (US)**

(30) Priority:

(54) **FLASH LIGHT APPARATUS**

(54) **APPAREIL A JET DE LUMIERE**

- SPECIFICATION -

TO ALL WHOM IT MAY CONCERN:

Be it known that I, EDGAR C. DODGE, of the City of Chicago, in the County of Cook, in the State of Illinois, Foreman, having invented certain new and useful improvements in

8 FLASH LIGHT APPARATUS

do hereby declare that the following is a full, clear, and exact description of the same.

This invention relates to that type of flash light apparatus used in photography, in which the illuminating powder is ignited by a resistance wire or strip heated by the passage of an electrical current there-
10 through; and it has for its objects to simplify devices of this character and to provide one which shall be exceedingly compact in form, so as to be readily
15 portable, and to generally improve the structure thereof.

The invention also contemplates the provision of a simple and novel plug, which is designed to introduce the resistance into the electric circuit and is
20 preferably provided with means for carrying a supply of such wire to be drawn upon and used as the wire is

burned off or fused at the end due to the passage of the current.

The invention consists of the combination and arrangement of parts hereinafter fully described, particularly designated in the claims and illustrated in the
5 accompanying drawings, in which

Fig. 1 is a perspective of the flash light apparatus;

Fig. 2 is a section on the line x--x of Fig. 1;

10 Fig. 3 is a longitudinal section on the line y--y of Fig. 1; and

Fig. 4 is a detail of the fuse plug.

The device is preferably carried by or mounted on a box or receptacle 10, of which the top, 11, provides a flash tray or surface on which the illuminating
15 powder to be ignited is placed. Such box provides a chamber for the reception of a battery 12, which may be of the ordinary dry cell type, used for supplying the electric current, and it also permits of the apparatus
20 being put up in compact form so as to be easily portable.

The box may be made of any suitable material, but wood is preferred owing to its lightness, and when used the top of the same or the flash tray is covered
25 with a fireproof covering or coating, such as the layer of asbestos 13. The top 11 is also provided with a

longitudinal groove or trough 14 designed to receive and retain the powder, which may be extended along said trough as the work being done may require. The rear wall of the groove 14 is preferably perpendicular, while the bottom thereof tapers upwardly to the surface 11. This throws the illumination toward the object being photographed and, by reason of the tapered bottom, avoids the projecting of a shadow in front of the light.

On the top of the box at the rear thereof is a pair of contact plates 15 and 16 in electrical connection with the battery 12, as hereinafter described; and such plates are spaced apart to receive a fusible resistance wire-carrying plug 17. One of the contact plates, as 16, may be located in a recess 18 cut in the top of the box, while the other, or 15, is secured to the top parallel with the plate 16 and bridging the recess 18, as shown in Fig. 3.

The fuse plug 17 is an important feature of the invention, and may be used in other connections than that shown, as, for example, in the place of an ordinary fuse plug to avoid the overloading of the wires of an electric circuit, it being inserted between a pair of terminals, similar to the plates 15 and 16, for introduction into the circuit to be protected. Such plug consists of a pair of plates 19 and 20, separated by

an insulating block 21. The wire, designated 22, which may be German silver, or some other material having sufficient electric resistance to insure its being heated to incandescence or any degree sufficient to ignite the powder before fusing, is carried around the inner end of the plug, coming into engagement with the plates 19 and 20, which, when the plug is in place, press the wire against the terminal plates 15 and 16, causing the wire to bridge the space between the latter and introducing the same into the circuit.

The inner end of the plug 17, when the latter is in position, extends to and supports the resistance wire in the groove 14, and in order to permit of the powder entirely surrounding the wire so as to insure its ignition the inner end of the insulating block is grooved, as at 23, spacing the wire passing between the plates from the insulating block 21, as shown in Fig. 2. In order to provide for a good connection between the wire 22 and the plates 15 and 16, the plug is made of tapering form.

If desired and for the convenience of the operator, inasmuch as the end of the wire will be burned off with each operation of the device, the plug 17 may be provided with means for carrying a supply of wire to be paid out or drawn upon as needed. Such means may take the form of a spool 24. This spool, in order to

permit of its removal upon the exhaustion of the wire, may be provided at the ends with lugs 25 seated in recesses 26 formed in a pair of ears 27 extending downwardly from the plate 19 back of the insulation block 21. The ears, being of metal, may be easily sprung apart when it is desired to remove one spool and insert a new one. The wire passes from the spool 24 up through a hole 28 in the plate 19 and is then carried over the top of such plate, around the inner end of the plug and under the lower plate 20, the plug then being inserted between the terminals 15 and 16 and pressing the wire against the latter, as heretofore described. As the end of the wire is burned off a small portion may be unwound from the spool for the succeeding operation.

To avoid short circuiting of the current through the powder, as might happen if the latter should touch both of the contact plates 15 and 16, the insulating block is carried beyond the end of the plate 19 and extended up flush with the top of the same, as at 29, and the plate 15 is covered with an incombustible insulating material, as asbestos, which overhangs the inner edge of the said plate and, the wire employed being exceedingly fine, practically closes the gap between it and the inner end of the insulating block, thereby preventing contact of the powder with the conducting plate

15. Contact with the other or the lower plate is then immaterial.

Located at one end of the box 10 is a spring plate 30 which is engaged by one pole of the battery 12, when the latter is in the box, and pressed into engagement with the terminal of a conductor 31 leading to a binding post 32 of the plate 15, while the other pole is put in circuit with a conductor 33 through the medium of a screw 34 passing through the other end of the box and the conductor 33 and engaging the said pole, the conductor 33 terminating at a binding post 35. A similar binding post 36 is connected by a wire 37 to the contact plate 15 through the medium of a binding post 37, which may also serve to secure the said plate 15 in position. The binding post 38 is designed to hold the plate 15 and is assisted by a bolt or pin 39. Any suitable circuit closer may be employed, such as the button 39, to which wires 40 lead from the binding posts 35 and 36.

The bottom of the box may be closed by a door 41, permitting of the removal of the battery 12 when exhausted.

I claim as my invention -

1. In a flash light apparatus, in combination, a tray, an electric circuit provided with terminals mounted on the tray, a resistance wire-carrying plug removably seated between the terminals, and a circuit closer in the circuit.

2. In a flash light apparatus, in combination, a tray, an electric circuit provided with terminals mounted on the tray, a wedge-shaped resistance wire-carrying plug removably seated between the terminals, and a circuit closer in the circuit.

3. In a flash light apparatus, in combination, a tray, an electric circuit provided with terminal plates spaced apart and mounted on the tray, a wedge-shaped plug removably seated between the plates, a resistance wire bridging the space between the plates and held against the same by the plug, and a circuit closer in the circuit.

4. In a flash light apparatus, in combination, a tray, an electric circuit provided with terminal plates spaced apart and mounted on the tray, a wedge-shaped plug removably seated between the plates and comprising a pair of plates insulated from each other, a resistance wire bridging the space between the said plates

and held against the same by the plug, and a circuit closer in the circuit. *

5. In a flash light apparatus, in combination, a tray having a groove, an electric circuit provided with a pair of spaced terminal plates parallel with the tray and located at the side of the groove, a plug, the forward end of which has a transverse groove, removably seated between the terminals and for holding in contact with the same and in the groove a resistance wire bridging the space between the said plates, and a circuit closer in the circuit.

6. In a flash light apparatus, in combination, a tray, an electric circuit provided with a pair of spaced terminal plates mounted on the tray, an insulating covering overhanging the inner edge of the outer of the plates, a plug removably seated between the plates and for holding in contact with the same a resistance wire bridging the space between the said plates, and comprising a pair of plates, and an insulating block separating the same and extending upwardly beyond the plate adjacent the outer terminal plate and meeting the overhanging edge of the insulation of the said terminal plate.

7. In a flash light apparatus, in combination, a tray, an electric circuit provided with terminals mounted on the tray, a resistance wire-carrying plug remov-

bly seated between the terminals, means on the plug for carrying a supply of wire, and a circuit breaker in the circuit.

8. In a flash light apparatus, in combination, a tray, an electric circuit provided with terminal plates spaced apart and mounted on the tray, a plug removably seated between the terminal plates and comprising a pair of plates and an insulating block separating the same, and a spool carried by the plug, a resistance wire wound on the spool and bridging the space between the terminal plates and pressed into contact with the same by the plug, and a circuit breaker in the circuit.

9. In a flash light apparatus, in combination, a tray provided with a groove having a vertical rear wall and an upwardly and forwardly inclined front wall, and igniting means located in the groove.

10. In a flash light apparatus, in combination, a box or casing the top of which provides a tray, an electrical igniting device mounted on the tray, conductors leading from the ends of the box and in circuit with the igniting device, a spring plate secured in the box and a "dry" battery in the box one of the poles of which presses the spring plate against the conductor at that end of the box, and a screw passing through the conductor at the other end of the battery and impinging the pole adjacent thereto.

11. In combination with a flash light apparatus, a tray, a pair of electrical terminals mounted thereon and spaced apart, a fuse wire bridging the space between the terminals, and a plug removably seated between the terminals and pressing the wire into contact therewith.

12. In combination with a flash light apparatus, a tray, a pair of electrical terminal plates mounted thereon and spaced apart, a plug comprising a pair of plates and an insulating block therebetween provided with a transverse groove at the forward end, and a fuse wire passing around the grooved end of the plug in engagement with the plates thereof and pressed by the latter into contact with the terminal plates.

13. In a flash light apparatus, in combination, a tray, a pair of electrical terminal plates mounted thereon, a plug removably seated between the terminal plates and comprising a pair of plates insulated from each other, means on the plug for carrying a supply of fuse wire, and a wire passing from such means around the end of the plug and pressed into contact with the terminal plates by the plug.

14. In a flash light apparatus, in combination, a tray, a pair of electrical terminal plates mounted thereon, a plug removably seated between the terminal plates and comprising a pair of plates, and an insulat-

ing block separating the plates and having a transverse groove at its forward end, a pair of ears projecting from one of the plug plates, a spool mounted between the ears, and a fuse wire passing from the spool, around the end of, the plug and pressed by the plates thereof into contact with the terminal plates.

15. In a flash light apparatus, a tray having a powder receiving channel, and a lateral igniter-receiving recess opening to such channel.

Clayton B. Deane

Chicago, Illinois,

December 12, 1933.

Witnesses:

Louise Jackson

E. M. Klatcher

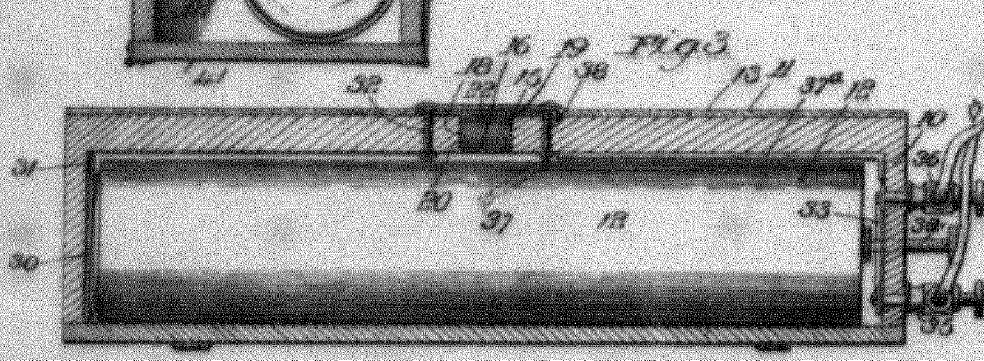
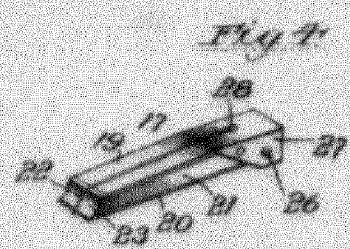
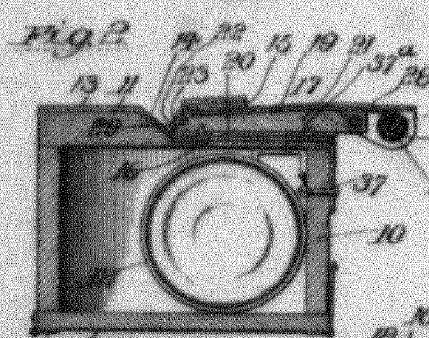
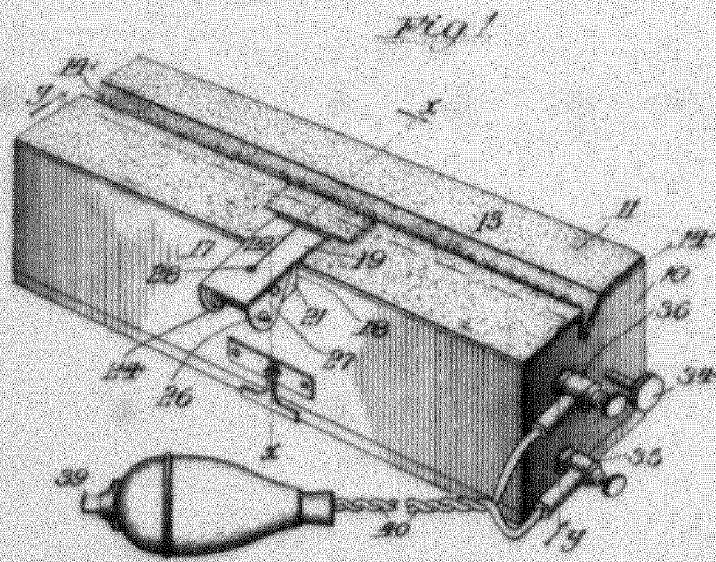

Witnesses:
 E. M. Clatcher
 J. W. Bristol

Certified to be the drawing referred to in the specification herewith annexed.
 Chicago, Ill., Dec. 8, 1903.

Edgar C. Dodge,
 Inventor,
 By Louis A. Green,
 His attorney