

D. C. SHOBERG.
 FLASH LIGHT APPARATUS.
 APPLICATION FILED MAR. 7, 1910.

970,358.

Patented Sept. 13, 1910.

3 SHEETS—SHEET 1.

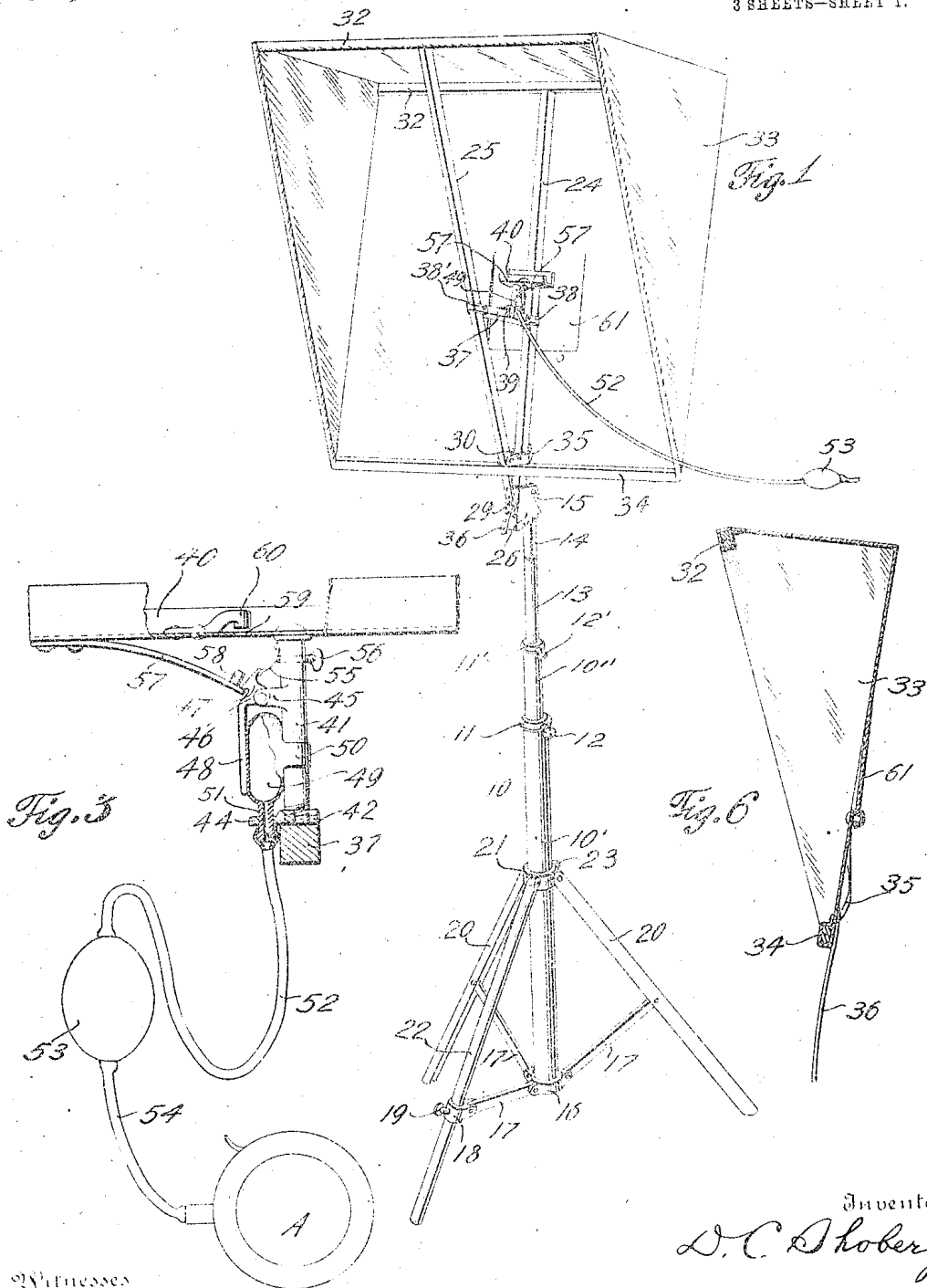

Witnesses

E. Larson

Charles Wilson

Inventor

D. C. Shoberg

Beeler Robb

Attorney

D. C. SHOBERG.
FLASH LIGHT APPARATUS.
APPLICATION FILED MAR. 7, 1910.

970,358.

Patented Sept. 13, 1910.

3 SHEETS—SHEET 2.

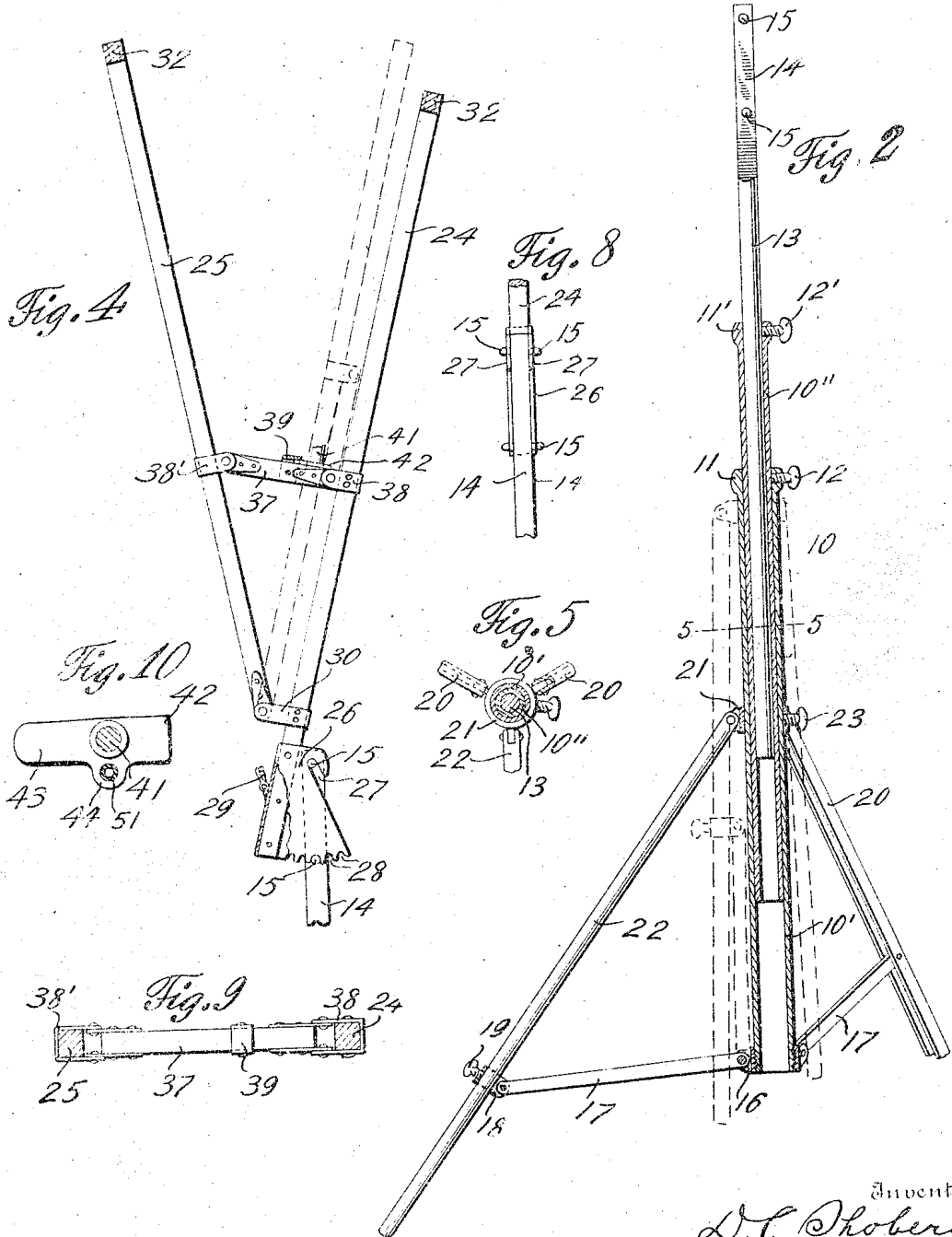

Witnesses
E. Larson
Charles Wilcox

Inventor
D. C. Shoberg
By *Beale Wood*
Attorney

D. C. SHOBERG.
FLASH LIGHT APPARATUS.
APPLICATION FILED MAR. 7, 1910.

Patented Sept. 13, 1910.

3 SHEETS—SHEET 3.

970,358.

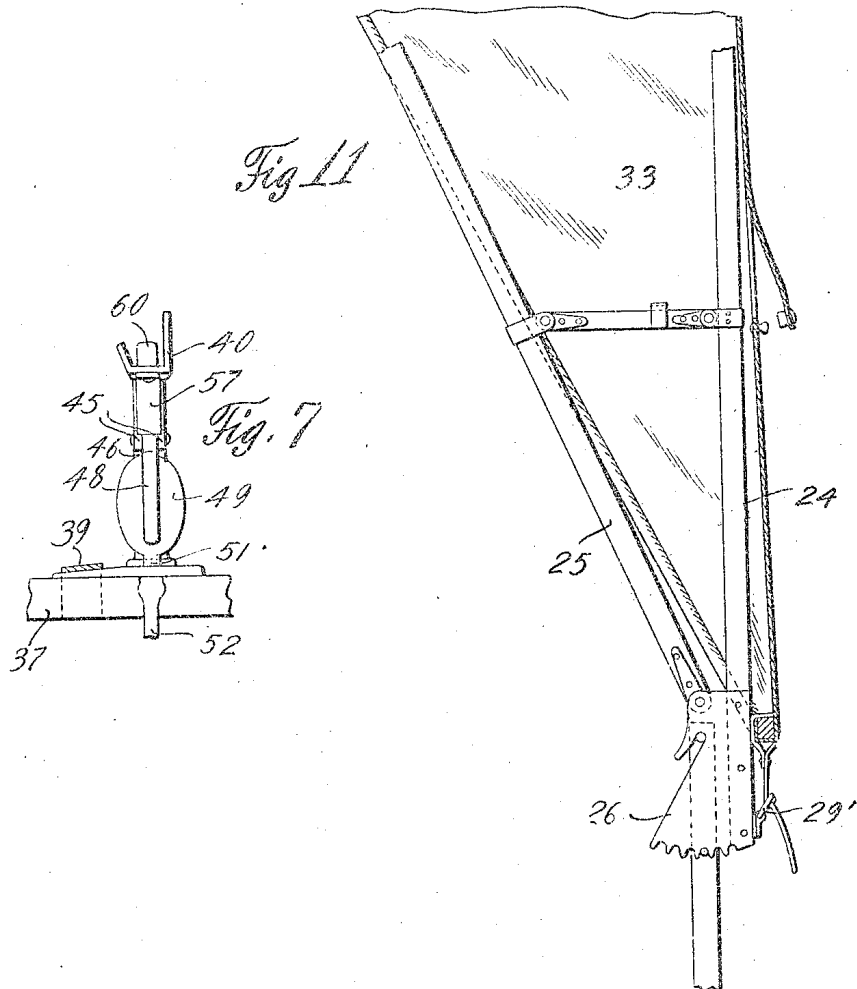

Fig. 11

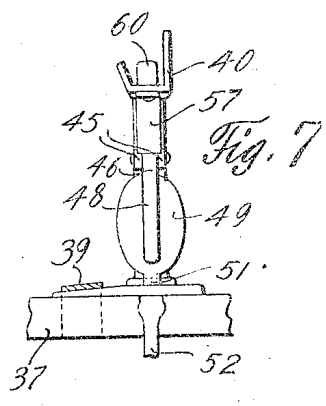

Fig. 7

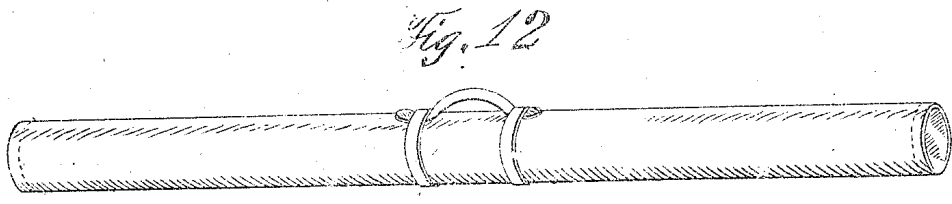

Fig. 12

Witnesses
Erson
Charles Wilson

Inventor
D. C. Shoberg
By *Becker & Coe*
Attorneys

UNITED STATES PATENT OFFICE.

DAVID C. SHOBERG, OF AVON, SOUTH DAKOTA.

FLASH-LIGHT APPARATUS.

970,358.

Specification of Letters Patent. Patented Sept. 13, 1910.

Application filed March 7, 1910. Serial No. 547,809.

To all whom it may concern:

Be it known that I, DAVID C. SHOBERG, a citizen of the United States, residing at Avon, in the county of Bonhomme and State of South Dakota, have invented certain new and useful Improvements in Flash-Light Apparatus, of which the following is a specification.

This invention has reference to appliances adapted for use by photographers, and particularly to that class of appliances for firing a charge of flash light powder in a hood.

The object of the present invention is to construct a device of this nature that is simple, light and inexpensive and which may be easily collapsed for traveling.

This invention also contemplates the construction of a flash light pan which may be timed with the shutter of the camera.

With the above and other objects in view, this invention consists of the construction, combination and arrangement of parts all as hereinafter more fully described, claimed and illustrated in the accompanying drawings, in which:

Figure 1 is a perspective view of a device constructed in accordance with the present invention; Fig. 2 is a side elevation partly in section of the adjustable standard; Fig. 3 is a front elevation partly broken away of the flash light firing mechanism, illustrating graphically the cooperation between the same and the shutter; Fig. 4 is a side elevation, partly in section, of the frame supporting the bag or hood, illustrating in dotted lines the position taken by the elements thereof when the same are folded; Fig. 5 is a transverse section of the adjustable standard, taken along line 5—5 of Fig. 2; Fig. 6 is a central section of the bag or hood; Fig. 7 is a side elevation of the operating means of the flash light firing mechanism; Fig. 8 is a rear elevation of the connection between the hood supporting frame and the adjustable standard; Fig. 9 is a top plan view of the bar supporting the flash light pan; Fig. 10 is a top plan view of the base of the standard supporting said flash light pan; Fig. 11 is a view similar to Fig. 4, illustrating the modification of the means for securing the hood to the supporting bars; Fig. 12 is a perspective view illustrating the device rolled.

Reference being had to the accompanying drawings, 10 indicates in general the adjust-

able standard which supplies a means whereby the hood may be supported. This standard comprises a main tubular section 10', the lower terminal of which is exteriorly threaded, while the upper terminal is provided with an enlargement 11, said enlargement having a set screw 12 threaded therein. A secondary tubular member 10'' reciprocates in said main section 10' and is retained at various heights therein by the set screw 12 operating in the enlargement 11. The upper terminal of the secondary section 10'' is constructed similar to the upper terminal of the section 10', being provided with the enlargement 11', in which is threaded the set screw 12'. Reciprocating in the tubular secondary section 10'' is the cylindrical support 13, said support adapted to be retained at various heights in the secondary section 10'' by the set screw 12'. The support 13 has the opposite sides 14 thereof flattened and the transverse pins 15 piercing the same adjacent to each extremity of said flattened portion. A collar 16 is mounted on the threads formed in the lower extremity of the main tubular section 10' and has pivotally connected thereto the bracing arms 17, said arms being adapted to brace the legs of the standard when the same are diverged. One of the arms 17 is provided with a sleeve 18 pivoted to the outer extremity thereof, said sleeve being provided with a set screw 19. A pair of legs 20 are secured to a collar 21 slidable on the main tubular section 10', said legs being of U-shaped metal and are secured to two of the arms 17. The remaining leg 22 is tubular in cross section, and reciprocates in the sleeve 18, said sleeve being retained in various positions thereon by the set screw 19. This leg is somewhat longer than the remaining legs and is so constructed that the level of the flash light hood and pan carried at the upper extremity of the standard 13 may be adjusted by changing the position of the sleeve 18 upon the leg 22. The collar 21 is provided with a set screw 23 which is adapted to retain said collar in any desired position on the main tubular section.

The frame supporting the flash light hood comprises a pair of converging standards 24 and 25. The standard 24 is detachably connected to the standard 13 of the adjustable support 10 by a U-shaped catch indicated in general as 26. This U-shaped catch

has the bar or standard 24 riveted therein adjacent the base portion thereof and is provided with the catch 27 in the arms on the upper sides thereof and the teeth or serrations 28 in the edges of the lower sides. The outer terminals of the U-shaped member slope from the serrations to the catch or hook 27. The hook 27 engages the upper of the transverse pins 15 while the teeth or serrations engage the lower pin, consequently doubly securing said bar to the standard 13 in such a manner that the angle of the same to the vertical may be varied. A buckle 29 is also carried by the U-shaped catch 26, and supplies a means whereby the hood carried by the frame may be tightened or drawn taut as hereinafter more fully described. The bar 25 is pivotally connected to the bar 24 adjacent the catch 26 by the bracket 30 rigidly secured to the latter. The lower terminal of the bar 25 is provided with the ears 31, said ears being provided with pins that are engaged by the openings in the outer terminals of the bracket 30.

Transverse bars 32 are mortised to the upper extremities of the bars 24 and 25, the bar 32 which is supported by the standard 25 having permanently secured thereto the upper edge of the hood or bag 33. This bag passes over the transverse bar 32 carried by the standard 24 and thence downwardly parallel thereto and has secured to the lower extremity thereof the base bar 34. The hood is provided with sides formed integrally therewith, the outer edges of which slope from the transverse bar 32 supported by the bar 25 to the base bar 34, forming a triangular construction. The base bar 34 is on the forward side of the bar 24, and the hood is pierced by the latter in order that the same may be within said hood. The opening 35 through which the bar 24 passes is rectangular in formation and of sufficient length to permit a slight reciprocation of the base bar 34 upon the vertical standard 24. The hood has attached thereto adjacent to the bar 34, the strap 36 which cooperates with the buckle 29 carried by the catch to tighten the bag over the supporting bars.

The flash light mechanism comprises a bar 37 pivotally connected to the bar 24 by the bracket 38, said bracket being rigidly secured to said bar. The opposite extremity of the bar is slidably mounted on the standard 25 by the bracket 38' pivotally connected to said bar. In order to provide a means whereby the flash light apparatus may be supported securely by said bar, a collar 39 is secured rigidly thereto, said collar being spaced from the upper side of the bar 37. The flash light pan 40 is secured to said bar by the post or stanchion 41, at the lower end of which is the base plate 42. This base plate is provided with the nose 43 which is received under the collar 39, securing said

stanchion and plate to said bar. An orificed projection 44 is provided on one side of the plate adjacent to the nose 43 and provides a means whereby the tube from the immediate bulb may be passed through said base plate and conducted past the bar.

The post or stanchion 41 is provided with the ears 45 between which is pivoted the catch 46. The catch comprises a double catch member 47 adjacent to the upper extremity of the stanchion and the downwardly projecting operating arm 48. The immediate operating bulb 49 is interposed between the arm 48 and the standard 41 and is secured to the latter by the band 50 engaging the same. The nipple 51 of the bulb extends through the orificed projection 44 of the base plate 42 and is connected below said plate and adjacent to the bar 37 to the tube 52 extending to the hand operated bulb 53. The opposite side of the bulb has the tube 54 extending therefrom to the shutter of the camera generally indicated as A. One side of the double catch member 47 has the spring 55 bearing thereagainst, the tension of said spring being adjusted by the set screw 56. The opposite or outer side of the double catch member 47 engages the firing pin spring 57 which is secured to the base of the flash light pan. This firing pin spring 57 carries the firing pin 58 adjacent to the extremity thereof which is engaged by the catch 46 when the flash light apparatus is set previous to the firing thereof. The firing pin is adapted to be projected through the opening 59 formed in the base of the firing pan and in contact with the anvil 60, a cap being interposed between the firing pin and the anvil 60 which will consequently be exploded when the same come in contact, firing the flash light powder in said pan. The hood back of the flash light pan is provided with a flap 61 which is fastened by snap catches on the lower edge thereof when not in use, said flap providing a means whereby the flash pan may be filled from the rear.

It will be observed from the foregoing that upon pressing the bulb 53, the arm 48 will be forced outwardly against the tension of the spring 55 releasing the firing pin spring and causing the cap to be exploded. At the same time air will be forced through the tube 54 operating the shutter A of the camera.

It will be understood that by regulating the tension of the spring 55 the flash light may be timed with the opening of the shutter in such a manner that the shutter will be opened previous to the flash, instantaneous with the flash, and after the flash at any period of time as desired.

When the adjustable standard is collapsed, the members 13 and 10' are contained within the section 10' while the legs 20' and 22 rest against the sides of said section, the

braces 17 thereof being interposed between the legs and said section. When folding the frame supporting the hood, the sleeve 38' slides upwardly on the bar 25 and when
5 folded the bar 37 is contained between the bar 25 and the bar 24, the latter resting approximately parallel to the construction of the bracket 30.

In the modification set forth in Fig. 11,
10 the forward sloping bar 25 is pivoted between the arms 26 and the U-shaped catch, while the vertical bar 24 is retained adjacent the base thereof. The hood 33 passes over the transverse bars and is secured to a buckle
15 29' carried on the base portion of the catch. This construction eliminates the necessity of piercing the hood in order to move the same to a position where it may cooperate with the buckle as set forth in Fig. 1.

20 Having thus fully described my invention, what is claimed as new is;

1. A flash light apparatus comprising, in combination, a support, a bar detachably secured to said support, a secondary bar
25 spaced from and pivoted to said bar, transverse bars detachably arranged at the upper extremity of said primary and secondary bars, a hood arranged over said bars having a transverse bar connected thereto at
30 the lower extremity, means whereby the tension of said hood over said transverse bars may be regulated, and a flash light apparatus detachably contained in said hood.

2. A flash light apparatus comprising, in
35 combination, a support, a bar detachably secured to said support, a secondary bar spaced from and pivoted to said bar, transverse bars detachably arranged at the upper extremity of said primary and secondary
40 bars, a hood arranged over said bars having a transverse bar connected thereto at the lower extremity, means whereby the tension of said hood over said transverse bars may be regulated, a transverse bar pivoted
45 between said primary and secondary bars, one extremity rigid with said primary bar and the opposite extremity slidable on said secondary bar, said bar adapted to be interposed between said primary and secondary
50 bars when the same are collapsed, and a

flash light firing apparatus detachably carried by said last named bar.

3. A flash light apparatus comprising, in combination, a support, a bar detachably secured to said support, a secondary bar
55 spaced from and pivoted to said bar, transverse bars detachably arranged at the upper extremity of said primary and secondary bars, a hood arranged over said bars having a transverse bar connected thereto at the
60 lower extremity, means whereby the tension of said hood over said transverse bars may be regulated, and a bar interposed between said primary and secondary bars, and adapted to collapse therewith, and a flash
65 light firing mechanism detachably carried by said bar.

4. A flash light apparatus comprising, in combination, a collapsible hood consisting
70 of a primary standard, a secondary standard pivoted to said primary standard and spaced therefrom, transverse bars carried at the upper extremity of said standards and a hood arranged over said bars having a base
75 bar secured thereon, a supporting bar interposed between the primary and secondary standards, having a collar thereon, the upper side thereof being spaced from said bar, and a flash light firing mechanism carried
80 on said bar.

5. A flash light apparatus comprising, in combination with a vertically adjustable
standard, a U-shaped catch member detachably carried at the upper extremity thereof,
85 means whereby said catch member is adjustable radially, a bar carried by said U-shaped catch member, a frame pivotally connected to said bar, a hood adapted to be retained over said frame, a horizontal bar adapted to normally retain the frame in a normally
90 operative position, and a flash light mechanism adapted to be detachably carried by said bar.

In testimony whereof I affix my signature in presence of two witnesses.

DAVID C. SHOBERG.

Witnesses:

H. H. KOEHN,
J. C. UNRUK.