(19)  **Canadian
Intellectual Property
Office**

An Agency of
Industry Canada

**Office de la Propriété
Intellectuelle
du Canada**

Un organisme
d'industrie Canada

(11) **CA 293227** (13) **A**

(40) **24.09.1929**

(12)

(21) Application number: **293227D**

(51) Int. Cl:

(22) Date of filing: ..

(71) Applicant: **CLERGY LOUIS.**

(72) Inventor: **CLERGY LOUIS ()**.

(54) **FLASH LIGHT GUN**

(57) **Abstract:**

(54) **APPAREIL A ECLAIRS**

This First Page has been artificially created and is not part of the CIPO Official Publication

S P E C I F I C A T I O N

To All Whom It May Concern:

Be it known that I, Louis Clergy, a citizen of the United States, and a resident of Des Moines, in the County of Polk, State of Iowa, United States of America, machinist have invented a certain new and useful

FLASH LIGHT GUN

of which the following is a specification:

This invention relates to improvements in flash light guns for use in photography, of the type employing an open pan for receiving the flash light powder, and a percussion cap or shell for igniting the powder when in the pan, and also employing a spring actuated hammer device for setting off the cap. Numerous accidents have occurred to operators using this type of gun, due to the accidental release of the hammer after it has been set, causing the flash light powder to be prematurely ignited, and sometimes resulting in serious injury to the operator.

It is, therefore, the object of my invention to provide a flash light gun of simple, durable and inexpensive construction, which is comparatively safe and which may be easily and quickly operated.

A further object is to provide in a flash light gun means whereby a number of percussion shells may be stored in such position with the powder pan that they may be easily

4

and quickly moved to operative position when desired.

A further object is to provide in a flash light gun improved means for actuating the hammer device.

A further object is to provide in a flash light gun detachable means which may be easily and quickly attached or removed for the purpose of automatically operating the shutters of a camera from the explosive force of the flash light powder, and to include therewith means whereby the ordinary shutter operating cable of a camera may be easily and quickly connected in operative relation with the automatic shutter operating device, said cable, when so attached, being adapted to transmit power obtained from the explosion of the powder to operate the shutter.

My invention consists in the construction, arrangement and combination of the various parts of the device, whereby the objects contemplated are attained, as hereinafter more fully set forth, pointed out in my claims, and illustrated in the accompanying drawings, in which:

Figure 1 is a longitudinal, central, sectional view of my improved device.

Figure 2 is a plan view of same.

Figure 3 is a front elevation of the upper end of my improved device showing the powder pan moved to its tilted position, said pan being shown in its normal position by dotted lines.

Figure 4 is a detail sectional view taken on the line 4--4 of Figure 1.

Figure 5 is a back view of the automatic shutter oper-

ating device removed from the pan.

Figure 6 is a side elevation of same.

Figure 7 is a detail sectional view taken on the line 7--7 of Figure 4.

My improved device comprises a rectangular casing 10, preferably formed of light sheet metal, having its lower end provided with an end plate 11 and its upper end open. The back edges of the side members of the casing 10 are each provided with a notch 12, which are in alinement with the openings 13 in the back plate 14 of the casing. The upper ends of the notches 12 are substantially at right angles to the back to form a shoulder to limit the movement of the hammer hereinafter described.

Supported in the casing 10 near its lower end is a bar 15 provided with an opening 16 for slidably receiving a rod 17. The upper end of the rod 17 is provided with a hammer 18 slidably mounted between the upper end of the back plate 14 and a block 19. The upper end of the hammer 18 is formed conical, while its back edge is provided with a downwardly extending flange 20 designed to cover the opening 12 when the hammer is in its elevated position. A spring 21 is mounted on the rod 17 for yieldably supporting the hammer 18 in its elevated position. The back edge of the hammer 18 is provided with a horizontal notch 22 designed to receive a roller 23 mounted on a pin 24. The said pin 24 is supported in bars 25, shown by dotted lines in Figure 1 and by solid lines in Figure 4. The lower ends of the bars 25 are secured to a collar 26 slidably mounted

6

on the casing 10. The said collar is provided with a finger piece 27 which provides means whereby the collar may be moved downwardly, which in turn will cause the roller 23 to be moved downwardly and the hammer 18 to be moved downwardly against the tension of the spring 21. As the roller moves downwardly it engages the inclined edges of the notches 12, which will cause the roller to disengage the notch 22 at the time the roller moves to the position outside of the upper end of the member 14. The hammer is at that time released and thrown upwardly by the spring 21, and caused to engage the cap 28 mounted in a cylindrical magazine 29.

The magazine 29 is rotatively mounted on a pivot 30 extending downwardly from the bottom 31 of the pan 32. The said pan is pivotally connected to the upper end of the casing 10 by means of a pivot 33, so that it may be swung from a horizontal to a vertical position, as shown in Figure 3. The pan is locked in its horizontal position by means of a spring actuated plunger 34 entering an opening 35 in the upper end of one of the side members of the casing 10. A knob 36 is provided on the opposite end of the plunger 34 by means of which the said plunger may be released from the opening.

The cylindrical magazine 29 is provided with a series of vertically arranged openings 37 arranged in a circular row concentric with the pivot 30. Each of the openings 37 is designed to receive the cap 28 which is in the form of a brass shell, such as used in fire arms.

1

The bottom member 31 of the pan 32 is provided with an opening 38 in alignment with the circular row of openings 37. The bottom 31 is provided with a downwardly extended flange 39 surrounding said opening, said flange being designed to enter an enlargement portion 40 at the upper end of each of the openings 37. A plate 41 is supported adjacent to the lower side of the magazine 29 and supports the caps 28 in position. The plate 41 is yieldably supported by means of a spring 42 on the shaft 30. The lower end of said spring rests on a bracket 43 supported on the bottom member 31 and supports the housing for the spring actuated plunger 34.

The plate 41 is provided with an elongated opening 44 for receiving the pan 30, so that the said plate may be slid relative to the magazine 29 by means of a downwardly extending lug 45. One edge of the plate 41 is provided with notches 46 and 47. The notch 46 is so located that when the plate 41 is moved to the position shown by dotted lines in Figure 7, the cap 28 may be inserted in the openings 37, after which the plate may be moved to the position shown by solid lines in Figure 7 and the caps retained therein. The notch 37 is cut away to permit a portion of that one of the caps above the hammer 18 to be exposed, to permit the pointed end of said hammer to strike one edge of the cap. The magazine may be rotated on the pivot 30 after the pan has moved to the tilted position shown in Figure 3 by simply grasping the edges of the magazine between the thumb and finger and sliding the magazine

outwardly from the bottom of the pan against the spring 42, causing the openings 40 to disengage the downwardly extending flange 39, said flange retaining the opening 37 in alignment with the opening 38. A spring 48 is provided, having one end attached to the upper end of one of the members 25 and the other end attached to the upper end of one of the side members of the casing 10 at the point 49. Said spring 48 retains the rollers 23 within the notch 22. The pan 32 is provided with an upwardly extending back plate 50 which serves as a reflector and also protects the operator against the flying particles of ignited powder. The powder is placed on the bottom of the pan 31 covering the opening 38, a portion of said powder flowing into the shell or cap 28. As the hammer is released, the cap will be set off and the powder ignited, causing an upward discharge.

To provide means whereby the shutters of the camera may be automatically operated from the explosive force of the powder, I have provided the following mechanism: The device comprises a plate 51 having a downwardly extending arm 52 and a horizontally extending arm 53. The upper end of the plate 51 is provided with a spacing bar 54 to which is secured a downwardly extending plate 55. The thickness of the bar 54 is substantially the same as the thickness of the plate 50, so that the member 54 may be supported on the upper edge of the member 50 with the plate 51 adjacent to the back of the plate 50, and the plate 55 adjacent to the front of the plate 50. The lower end of said plate 55 extends near the bottom of the pan 31. The lower end

9

of the plate 55 is provided with a ring 56, the lower edge of which is supported upon the upper surface of the bottom 31 in such a manner that one edge of the ring passes over the opening 38, so that the said opening will communicate with the interior of said ring and also with the interior of the pan 32 outside of the ring. Pivotaly mounted on the inner face of the arm 53 is a lever 57 having one end projecting inwardly and downwardly to a point above the ring 56, and terminating in a disk 58 supported normally to close the upper end of the ring 56, and is adapted to be moved in said position after the ring 56 and the pan 32 have been filled with powder. The arm 57 is provided with an outwardly extending pin 59 which extends through a slot 60 in the upper edge of the arm 53, and designed to enter an elongated opening 61 in one end of a lever 62 pivoted to the back side of the arm 53 by means of a pivot 53. The free end of the arm 62 terminates at a point above the arm 52 and above the clamp 64 carried by said arm, said clamp being designed to receive a shutter operating cable 65, such as commonly used for the hand operation of the camera shutters. The cable is clamped in such a manner that a finger piece 66 of said cable is supported above the clamp and a thumb piece 67 is caused to engage the under surface of the free end of the lever 62, when the said thumb piece 67 is in its normal position.

By this arrangement it will be seen that when the powder within the pan 32 and the ring 36 is ignited, the explosion will cause the disk 58 to be thrown upwardly to the position

shown by dotted lines in Figure 3, against a stop pin 68, and the outer end of the lever 62 to be elevated, while its inner end is lowered, causing the thumb piece 67 to be moved toward the finger piece 66 and the actuating rod of the cable 65 to be operated in the usual manner. The cable, of course, is assumed to be operatively connected with the shutters. The automatic shutter operating device may be easily and quickly attached to or detached from the plate 50 by means of a set screw 69.

Thus it will be seen that I have provided a flash light gun of simple, durable and inexpensive construction, and one which is comparatively safe to operate, for the reason that at no time is the hammer 18 automatically set or locked, as is the usual practice. The camera is moved to, and retained in, operative position only when pressure is actually being applied to the finger piece 27. The spring 21 is of such tension that it is necessary to exert considerable pressure in order to bring the roller 23 to a position where it will be released from the notch 22. The casing 10 is of such diameter as to be easily grasped in the operator's hand, while the finger piece 27 may be operated by one of the fingers, so that the gun is supported and operated by one hand, with the casing 10 in an upright position.

By providing the rotatively mounted magazines 29, I have provided means whereby a number of shells or caps may be carried in a convenient position where they may be easily and quickly moved to operative position each time the pan is

filled with powder, and I have found by actual experience that this type of cap is a great deal more positive in its operation than the dynamite paper caps which are quite commonly used.

A considerable advantage is gained by making the shutter operating mechanism detachable, as in ordinary use this device is not required, and it is so constructed and arranged that it is very positive in its action, and will operate the shutters at the time the greatest intensity of light occurs, which is a very desirable feature in devices of this kind.

Substantially all of the gun is constructed of thin sheet metal, which may be stamped and formed by the die process, and for that reason is light and comparatively strong.

I claim as my invention:

12

- 1 -

A flash light gun comprising a support, a powder pan having an opening in its bottom, a downwardly extending pivot, a magazine for containing caps rotatively mounted on said pivot, said magazine being provided with a series of vertically arranged openings, a plate slidably mounted adjacent to the lower end of said magazine, yieldable means on said shaft for supporting said plate, one edge of said plate being provided with notches, a hammer for engaging a cap mounted in said magazine, and means for actuating said hammer.

- 2 -

A flash light gun comprising a pan for receiving flash light powder, means for igniting the powder within said pan, means actuated by the explosion of said flash light powder for automatically operating a camera shutter, said means comprising a frame, means for detachably connecting the frame to said pan, said frame including a ring supported in said pan and adapted to receive a portion of the flash light powder, a lever pivotally connected to said frame, the free end of said lever being provided with a disk for covering the upper end of said ring, and means actuated by said lever for operating the camera shutter.

- 3 -

A flash light gun comprising a pan for receiving flash light powder, means for igniting the powder within said pan, means actuated by the explosion of said flash light powder for automatically operating a camera shutter, said means comprising a frame, means for detachably connecting the frame to said pan, said frame including a ring supported in said pan and adapted

13

to receive a portion of the flash light powder, a lever pivotally connected to said frame, the free end of said lever being provided with a disk for covering the upper end of said ring, means for detachably clamping a shutter operating cable having a push wire to said frame, and means actuated by said lever for operating said push wire.

- 4 -

A shutter operating mechanism for flash light guns comprising a plate having a horizontally extending arm and a downwardly extending arm, a second plate spaced apart from the first said plate and having its upper edge attached to the upper edge of the first said plate, the lower end of the second plate being provided with a horizontal ring, a lever pivotally connected to the outer end of said horizontal arm having its free end extending inwardly and terminating above said ring, the free end of said lever being provided with a disk for covering said ring, a second lever pivotally connected to the back of said horizontal arm having its outer end operatively connected with the first said lever, a clamping device secured on the lower end of said downwardly extending arm and beneath the inner end of the second said lever.

- 5 -

A shutter operating mechanism for flash light guns comprising a plate having a horizontally extending arm and a downwardly extending arm, a second plate spaced apart from the first said plate and having its upper edge attached to the upper edge of the first said plate, the lower end of the second plate being provided with a horizontal ring, a lever pivotally connected

14

to the outer end of said horizontal arm having its free end extending inwardly and terminating above said ring, the free end of said lever being provided with a disk for covering said ring, a second lever pivotally connected to the back of said horizontal arm having its outer end operatively connected with the first said lever, a clamping device secured on the lower end of said downwardly extending arm and beneath the inner end of the second said lever, and a shutter operating cable secured in said clamp, said cable being provided with a push wire designed to normally engage the inner end of said second lever.

- 6 -

In a flash light gun, a casing having notches in each side and terminating in an opening in the back of said casing, said notches being provided with inclined edges, a hammer slidably mounted within said casing and past said opening, the back edge of said hammer being provided with a notch in alinement with said opening, a collar slidably mounted on said casing, a roller resting normally within the notch of said hammer and within the notches of said casing, links for connecting the ends of said roller with said slidable sleeve.

- 7 -

In a flash light gun, a casing having notches in each side and terminating in an opening in the back of said casing, said notches being provided with inclined edges, a hammer slidably mounted within said casing and past said opening, the back edge of said hammer being provided with a notch in alinement with

15
said opening, a collar slidably mounted on said casing, a roller resting normally within the notch of said hammer and within the notches of said casing, links for connecting the ends of said roller with said slidable sleeve, a flash light powder pan supported on said casing, said pan being provided with an opening, and means for supporting a cap in alinement with said opening and in alinement with said hammer.

Louis Clergy
Inventor.

In the presence of

Bernice Russell
Sidney Griffiths

Des Moines, Iowa,
March 18, 1929.
AGH:RE.

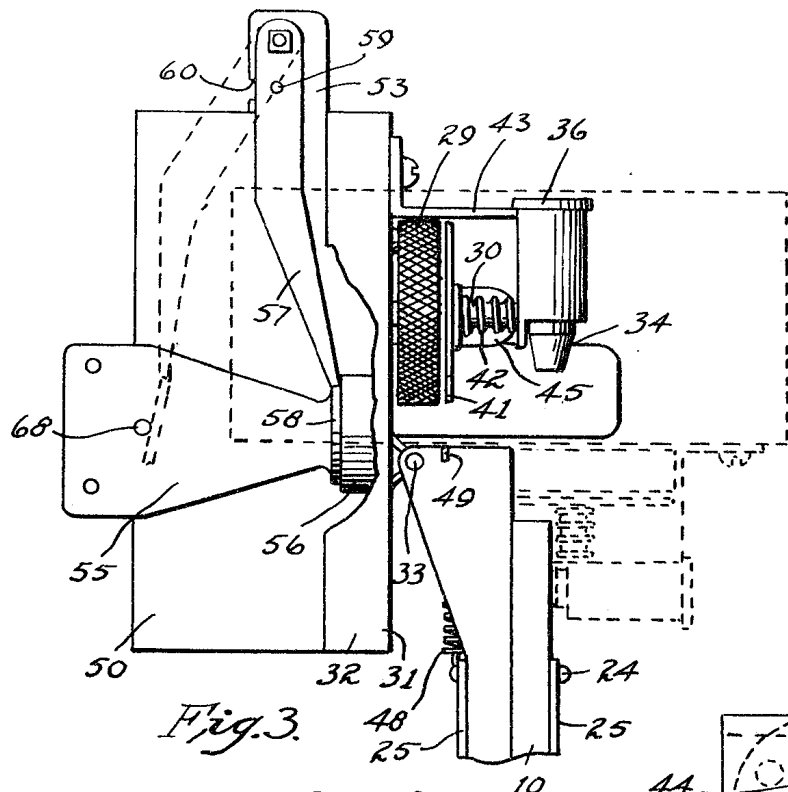

Fig. 3.

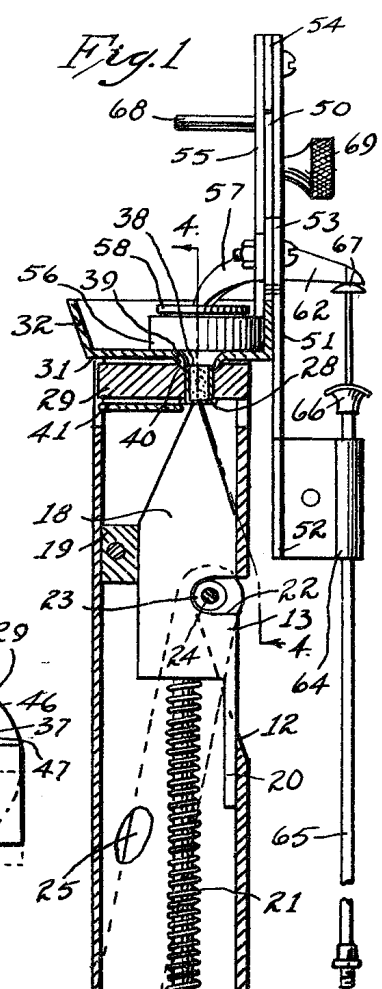

Fig. 1.

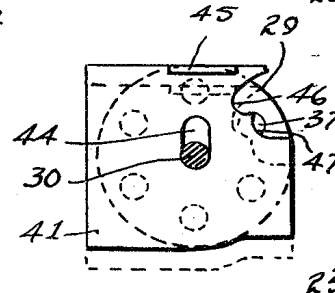

Fig. 7.

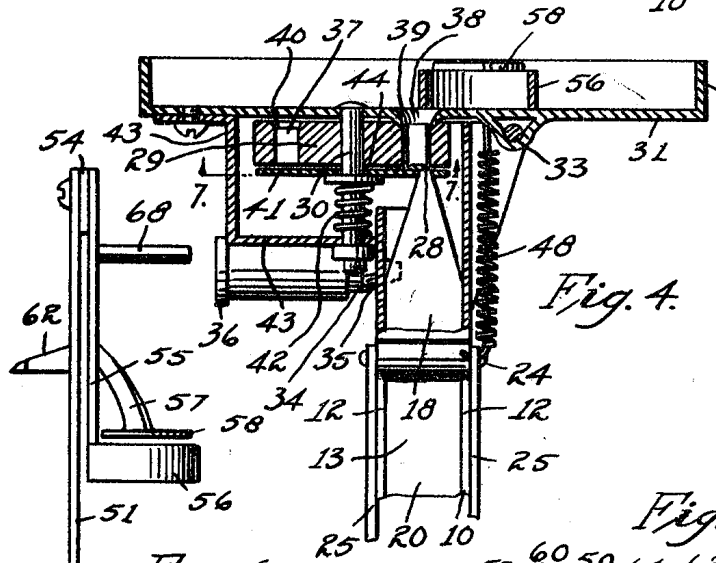

Fig. 4.

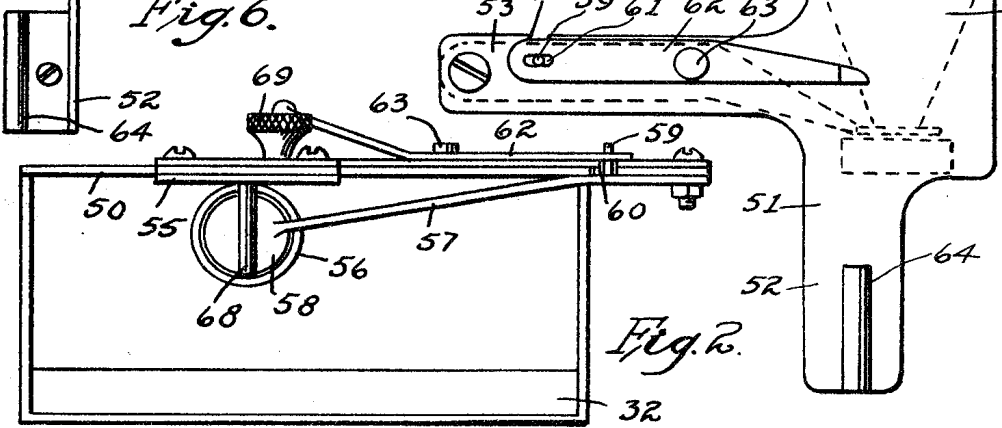

Fig. 2.

Certified to be the drawing referred to in the specification herunto annexed:
Des Moines, Iowa. 3-23-29.

Inventor:
Louis Clergy

by Orwig & Kague Atty's.