

No. 846,540.

PATENTED MAR. 12, 1907.

A. WOLLENSAK.
PHOTOGRAPHIC SHUTTER.
APPLICATION FILED JUNE 23, 1906.

2 SHEETS—SHEET 1.

FIG. 1.

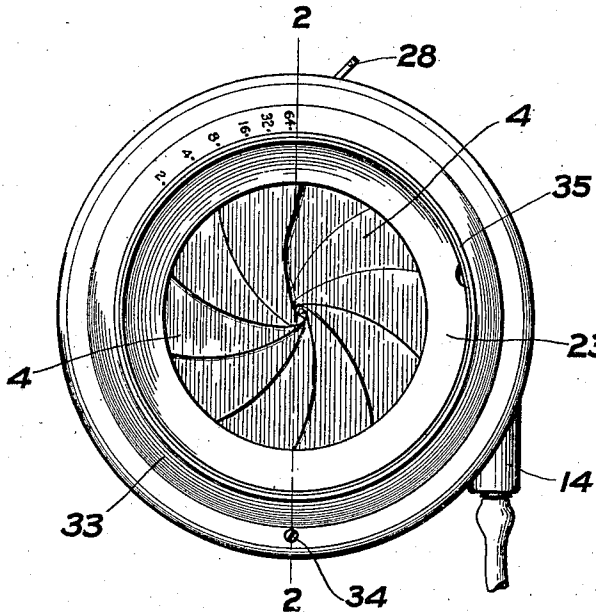

FIG. 2.

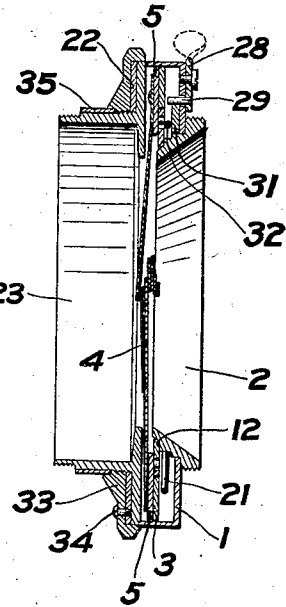

FIG. 3.

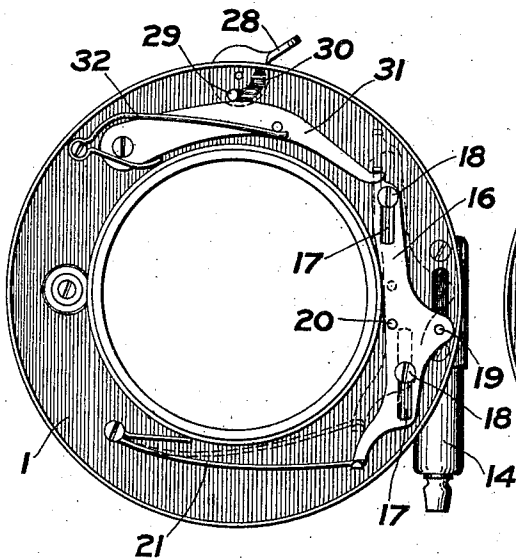
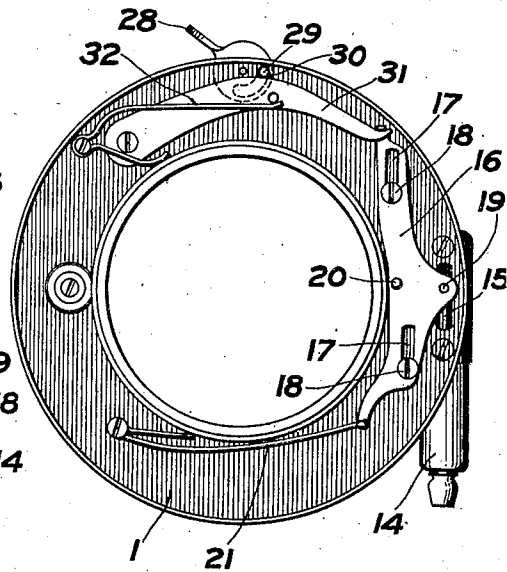

FIG. 4.



WITNESSES:

Clarence W. Carroll
L. P. Ross.

INVENTOR:

Andrew Wolleusk
by O'Connell & Davis
his Attys

No. 846,540.

PATENTED MAR. 12, 1907.

A. WOLLENSAK.
PHOTOGRAPHIC SHUTTER.
APPLICATION FILED JUNE 23, 1906.

2 SHEETS—SHEET 2.

FIG. 5.

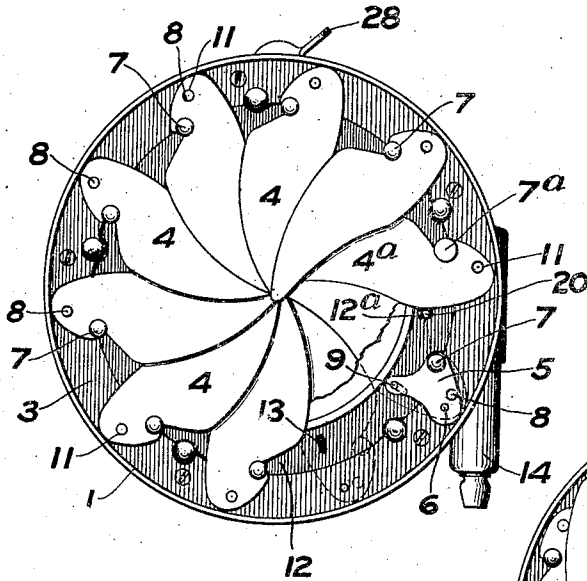

FIG. 6.

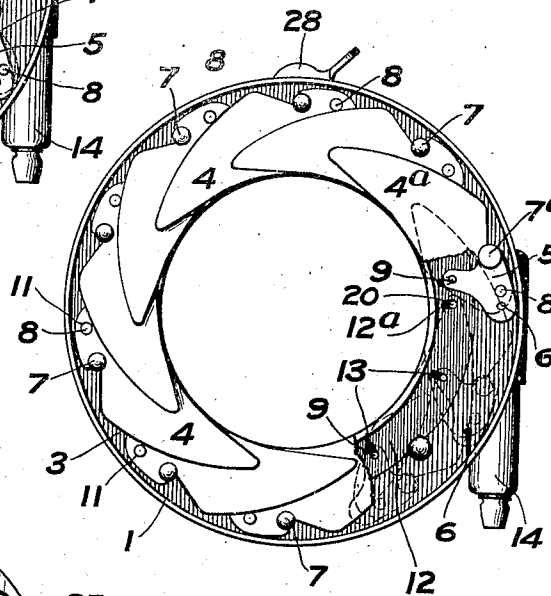

FIG. 7.

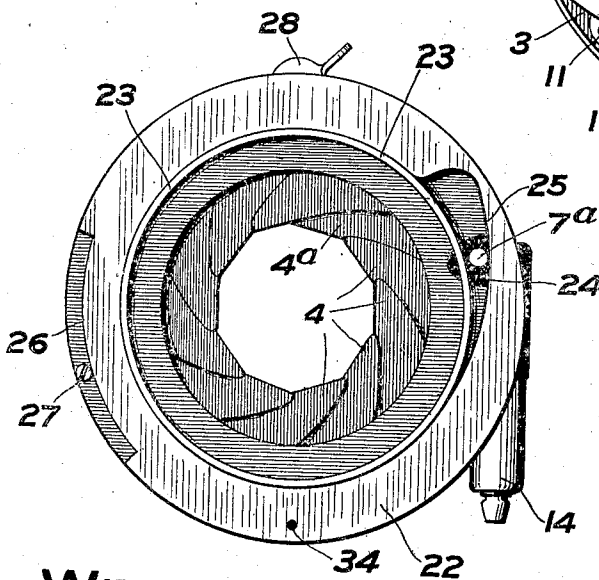
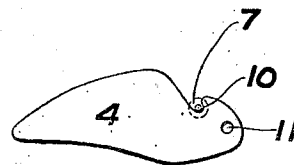

FIG. 8.



WITNESSES:

Clarence W. Carroll.
L. Thon

INVENTOR:

Andrew Wolleusak
by Osgood & Davis
his attorney

UNITED STATES PATENT OFFICE.

ANDREW WOLLENSAK, OF ROCHESTER, NEW YORK, ASSIGNOR TO WOLLENSAK OPTICAL COMPANY, OF ROCHESTER, NEW YORK, A CORPORATION OF NEW YORK.

PHOTOGRAPHIC SHUTTER.

No. 846,540.

Specification of Letters Patent.

Patented March 12, 1907.

Application filed June 23, 1906. Serial No. 323,074.

To all whom it may concern:

Be it known that I, ANDREW WOLLENSAK, a citizen of the United States, and a resident of Rochester, in the county of Monroe and State of New York, have invented certain new and useful Improvements in Photographic Shutters, of which the following is a specification.

This invention relates to photographic shutters, and consists in the mechanism hereinafter described and claimed.

The object of the invention is to provide a simple and efficient shutter, particularly intended for portrait-work, but equally suitable for work of other kinds.

In the drawings, Figure 1 is a rear elevation of a device embodying this invention. Fig. 2 is a vertical section on the line 2 2 of Fig. 1. Fig. 3 is a rear elevation of the parts in the normal position with the shutter closed, parts of the casing being removed in order to exhibit the internal construction. Fig. 4 is an elevation of the same character as Fig. 3, but with the parts in the position for focusing. Fig. 5 is an elevation of the device, parts being removed in order to show the shutter-leaves in the closed position. Parts of the leaves are removed in order to show the construction underneath them. Fig. 6 is an elevation showing the same parts as in Fig. 5, but showing the shutter-leaves open. Fig. 7 is an elevation of the device, parts being removed to show the shutter-leaves partly open for the purpose of acting as a diaphragm; and Fig. 8 is a plan view of one of the shutter-leaves, showing also by dotted lines one of its bearing-studs.

The device has a circular casing 1, provided with the conical front 2. The said casing nearest the front contains the actuating apparatus to be described below, and behind a wall or diaphragm 3 contains the series of iris-leaves 4. Each leaf is carried by a metallic supporting-plate 5, Fig. 5, which is pivoted at 6 to said diaphragm 3. The plate 5 carries two studs 7 and 8 and a pin 9. The stud 7 is peripherally grooved or notched so that the notched portion 10 of the blade may rest in said groove. The stud 8 fits in a perforation 11 in the blade. The blades are made of flexible thin material,

sufficiently rigid for the purpose, and thin ebonite is suitable therefor. By bending the blade so as to slip it off from the pin or stud 8 it may then be removed from the groove or notch in the stud 7 and lifted out of the apparatus. In the diaphragm or wall 3 is guided and turns a ring 12. This ring lies close against the surfaces of the leaf-plates 5 and is provided with a series of substantially radial slots 13, into which project the pins 9 of the leaf-plates 5. It will be seen that by moving the operating ring or plate 12 all of the blades will be moved to swing out and away from the optical center and that all of said blades will move in unison from the position shown in Fig. 5 to the position shown in Fig. 6. One of the blades 4^a has upon its supporting-plate 5 a stud 7^a, that extends upward above the plane of all the plates, for a purpose hereinafter described.

In order to operate the shutter, the casing 1 carries a pump-body 14, having a movable portion 15, that engages a reciprocating slide 16, carried on the inside of said casing 1. The slide has a pair of slots 17 set in the same or parallel lines, through which pass screws 18 to hold the plate against the casing 1 and to guide it. A pin 19 on said plate may connect with the movable part 15 of the pump, and a pin 20, carried by said plate, extends into a slot 12^a in the operating-ring 12. A spring 21 is fastened to the casing and engages the plate 16 to lower it into the position shown in full lines in Fig. 3. The pump operation moves said plate upward into the position shown in dotted lines in said Fig. 3.

The operation of the parts hereinbefore described is as follows: The spring 21 holds the blades 4 closed in the position shown in Figs. 1 and 5. On operating the pump or actuator the plate 16, through the pin 20, moves the operating-ring 12 and turns it, whereby the leaf-plates 5 are rocked on their pivots 6 and the blades open to the position shown in Fig. 6. As long as the actuator keeps the parts in this position the blades will remain open; but as soon as the restraining force is removed the blades close instantly under the action of the spring 21. Ordinarily the operation is entirely a bulb operation, which is

well known to all photographers. This operation may of course be produced mechanically or electrically instead of pneumatically.

The use of diaphragms for reducing the amount of light that reaches the sensitive plate in a camera is well known, and means are therefore provided for stopping the opening movement of the leaves in this device at different areas of opening, so that the same device will perform the function of the diaphragm and of the shutter. This mechanism is shown in Fig. 7. The back of the apparatus is formed of the flanged screw-tube 23, having an opening 24, Fig. 7, through which projects the stud 7^a, above described, and of such a size as to permit said stud to move freely through its full arc of oscillation. The ring 22 has a long cam-surface 25, which may be turned to stop the movement of the stud 7^a, so as to shorten its oscillation. The said ring 22 is provided with means for limiting its rotary movement, and the specific means herein shown are the notch or peripheral slot 26 in the ring and the stud or screw 27 on the flange of the flanged tube 23. The ring 22 may turn until either end of the slot 26 strikes the stud or pin 27. It will now be obvious that according as the cam-surface 25 limits the opening movement of the shutter-blades the aperture to which said blades may open can be adjusted as desired. In Fig. 6 the blades are shown open to their maximum extent, and in Fig. 7 the ring 22 has been turned so as to permit the blades to open to about half the maximum. Means are provided for opening and closing the said blades by hand and also for holding them open. The specific embodiment of this portion of the invention is shown most clearly in Figs. 3 and 4. On the front of the casing 1 is pivoted a lever 28, having a pin 29 passing into the interior of the casing through the slot 30. Inside the casing 1 is the lever 31, pivoted to said casing and at its free end engaging the plate 16. A spring 32, that is stronger than the spring 21, actuates the lever 31 to cause it to raise the pin 20 into the position shown in Fig. 4, thus opening all the shutter-leaves to the maximum and holding them open. When the lever 28 is turned so that the pin 29 engages and depresses the lever 31, the spring 21 pulls the pin 20 downward and the parts take the position shown in Fig. 3, where they are ready for the ordinary bulb action hereinbefore described.

If the adjusting-ring 22 has been set, for instance, to the position shown in Fig. 7, then the turning of the lever 28 to the position shown in Fig. 4 will cause the lever 31 to move the pin 20, and thus to move the blades until they take the position shown in Fig. 7. Thus the focusing can occur under such reduced diaphragm-aperture as may be desired, and the blades will be held in the position to which they are set.

In order to set the adjusting-ring 22 to produce the various areas of opening above described, a ring 33 is carried by the flanged tube 23, and a pin or screw 34 connects said setting-ring 33 with the adjusting-ring 22. Upon the said setting-ring 33 are the series of numerals shown in Fig. 1, representing a usual notation for various diaphragm openings, and upon said tube 23 is placed a mark (not shown) to which the said numerals may, respectively, be set. A convenient mode of fastening the setting-ring 33 in place is by means of a retaining-ring 35, that is shrunk or driven or otherwise fastened upon the tube 23.

What I claim is—

1. In a photographic shutter, a casing having an aperture, shutter-blades pivoted to said casing and adapted to close said aperture, means connected to each blade for opening and closing the blades, spring means for closing the blades, stronger spring means for opening the blades, and mechanism for throwing said stronger spring means out of operation.

2. In a photographic shutter, a casing having an aperture, a series of shutter-blades pivoted to said casing and adapted to close said aperture, a ring connected to each blade for opening and closing the same, spring means for actuating said ring to close the blades, stronger spring means for actuating said ring to open the blades, and mechanism for throwing said stronger spring means out of operation.

3. In a photographic shutter, a casing having an aperture, a series of shutter-blades pivoted to said casing and adapted to close said aperture, a rotary ring in said casing connected to each blade for opening and closing the blades, spring means for actuating the ring to close the blades, stronger spring means for actuating said ring to open the blades, and mechanism for throwing said stronger spring means out of operation.

4. In a photographic shutter, a casing having an aperture, a series of shutter-blades pivoted to said casing and adapted to close said aperture, a rotary ring in said casing having a slot-and-pin connection to each blade for opening and closing the blades, spring means for actuating the ring to close the blades, stronger spring means for actuating the ring to open the blades, and mechanism for throwing said stronger spring means out of operation.

5. In a photographic shutter, a casing having an aperture, a series of shutter-blades pivoted to said casing and adapted to close said aperture, a rotary ring in said casing connected to each blade for opening and closing the blades, an operating-plate in said casing connected to said ring, a spring connected to said operating-plate for closing the blades, a stronger spring connected to said

plate for opening the blades, and mechanism for throwing said stronger spring out of operation.

5 6. In a photographic shutter, a casing having an aperture, a series of shutter-blades pivoted to said casing and adapted to close said aperture, means connected to each blade for opening and closing the blades, spring means for closing the blades, stronger spring means for opening the blades, mechanism for throwing said stronger spring means out of operation, and adjustable stopping means for stopping the opening movement of said blades.

15 7. In a photographic shutter, a casing having an aperture, a series of shutter-blades pivoted to said casing and adapted to close said aperture, a ring connected to each blade for opening and closing the same, spring means for actuating said ring to close the blades, stronger spring means for actuating said ring to open the blades, mechanism for throwing said stronger spring means out of operation, and a movable ring having an eccentric cam-surface in the path of a part moving with said blades for limiting the opening movement thereof.

30 8. In a photographic shutter, a casing having an aperture, a series of shutter-blades pivoted to said casing and adapted to close said aperture, a rotary ring in said casing connected to each blade for opening and closing the blades, spring means for actuating the ring to close the blades, stronger spring means for actuating said ring to open the blades, mechanism for throwing said stronger spring means out of operation, and a movable ring having an eccentric cam-surface in the path of a part moving with said blades for limiting the opening movement thereof.

40 9. In a photographic shutter, a casing having an aperture, a series of shutter-blades pivoted to said casing and adapted to close said aperture, a rotary ring in said casing having a slot-and-pin connection to each blade for opening and closing the blades, spring means for actuating the ring to close the blades, stronger spring means for actuating the ring to open the blades, mechanism for throwing said stronger spring means out of operation, and a movable ring having an eccentric cam-surface in the path of a part moving with said blades for limiting the opening movement thereof.

55 10. In a photographic shutter, a casing having an aperture, a series of shutter-blades pivoted to said casing and adapted to close said aperture, a rotary ring in said casing connected to each blade for opening and closing the blades, an operating-plate in said casing connected to said ring, a spring connected to said operating-plate for closing the blades, a stronger spring connected to said plate for opening the blades, mechanism for throwing said stronger spring out of operation, and a

movable ring having an eccentric cam-surface in the path of a part moving with said blades for limiting the opening movement thereof.

70 11. In a photographic shutter, a casing having an aperture, a series of shutter-blades pivoted to said casing and adapted to close said aperture, a rotary ring in said casing connected to each blade for opening and closing the blades, spring means for actuating the ring to close the blades, stronger spring means for actuating said ring to open the blades, mechanism for throwing said stronger spring means out of operation, and a movable ring having an eccentric cam-surface in the path of a part connected with one of said blades for limiting the opening movement of the series of blades.

80 12. In a photographic shutter, a casing having an aperture, a series of shutter-blades pivoted to said casing and adapted to close said aperture, a rotary ring in said casing having a slot-and-pin connection to each blade for opening and closing the blades, spring means for actuating the ring to close the blades, stronger spring means for actuating the ring to open the blades, mechanism for throwing said stronger spring means out of operation, and a movable ring having an eccentric cam-surface in the path of a part connected with one of said blades for limiting the opening movement of the series of blades.

95 13. In a photographic shutter, a casing having an aperture, a series of shutter-blades pivoted to said casing and adapted to close said aperture, a rotary ring in said casing connected to each blade for opening and closing the blades, an operating-plate in said casing connected to said ring, a spring connected to said operating-plate for closing the blades, a stronger spring connected to said plate for opening the blades, mechanism for throwing said stronger spring out of operation, and a movable ring having an eccentric cam-surface in the path of a part connected with one of said blades for limiting the opening movement of the series of blades.

100 14. In a photographic shutter, a casing, blade-supports pivoted to said casing, each support having a stud and a groove, a blade for each support engaging in said groove and having a perforation to fit upon said stud, whereby the blade is held in place and is removable from said plate, and means for operating said blades.

115 15. In a photographic shutter, blade-supports pivoted to said casing, each support having a circumferentially-grooved pin and a stud, a blade for each support having a portion fitting in said groove and a perforation fitting upon said stud, whereby the blade is held in place and is removable from said plate, and means for operating said blades.

120 16. In a photographic shutter, a casing, 130

blade-supports pivoted to said casing, each
 blade-support having a circumferentially-
 grooved pin and a stud, a blade for each sup-
 port having a notch in its edge and a perfora-
 5 tion, whereby when the notch in the edge of
 the blade rests in the groove of the pin and
 the perforation fits upon the stud the blade

is held in place and is removable from said
 plate, and means for operating said blades.

ANDREW WOLLENSAK.

Witnesses:

D. GURNEE,
 H. L. OSGOOD.