

PATENT SPECIFICATION

228,535

Convention Date (France): Feb. 2, 1924.

Application Date (in United Kingdom): Jan. 26, 1925. No. 2288/25.

Complete Accepted: July 30, 1925.



COMPLETE SPECIFICATION.

Device for Photographing Titles upon Cinematographic Films.

We, PATHÉ CINÉMA ANCIENS ÉTABLISSEMENTS PATHÉ FRÈRES, 30, Boulevard des Italiens, Paris, France, a company organised under the laws of France,
5 Manufacturers, do hereby declare the nature of this invention and in what manner the same is to be performed, to be particularly described and ascertained in and by the following statement:—

10 When titles are to be provided upon a cinematographic film, the titles are photographed upon separate strips which are then interposed in the film and cemented to the same. This result can
15 be obtained with facility in the studio, the operator photographs, between each scene, a suitable panel upon which the title of the scene has been inscribed. But when taking views in the field, this
20 method cannot be employed, and this is particularly the case for amateur work, so that a simple device of a portable nature becomes necessary.

It has already been proposed to use
25 devices wherein the title is photographed during the taking of the views; in this case, the title extends over a part of the place reserved for the view.

The present invention relates to a
30 portable device of a simple character whereby successive reproductions of the title having each the same size as a view may be photographed immediately before the view-taking operation, in their
35 proper place upon a certain length of film. Said device comprises a flat shelf on which are hinged on one side a collar adapted to be secured to the lens of the cinematographic camera and on the other
40 side a frame wherein is mounted a screen of glass, celluloid or other suitable material, said frame being adapted to be folded down upon said flat shelf so as to be removed from the field of the lens,
45 whereby said shelf may be used as a desk

to inscribe on the screen the title to be photographed.

The titles which are thus photographed immediately before the taking of views will appear after development in their
50 proper place and can be suitably projected upon the screen. This method will greatly simplify the work required of the amateur.

In the appended drawing which shows
55 by way of example an embodiment of the invention:

Fig. 1 is an elevational view of the device according to the invention
60 mounted upon a cinematographic camera and in the operative position.

Fig. 2 is the corresponding plan view.

Fig. 3 is an elevational view of the device in the inoperative position, and

Fig. 4 is a plan view corresponding to
65 Fig. 3.

1 is the main body of the device. At one end of the same is pivoted a support or frame 4 containing a small screen 5 of glass, celluloid or other suitable material,
70 To the other end of the said main body is pivoted an attaching collar 2 whereby the said device may be mounted upon the lens of the cinematographic camera, said
75 collar being secured in position by means of the set screw 3. To the said main body 1 may also be secured the portrait hood 6 in order to obviate all risk of misplacing the same when it is not employed
80 with the apparatus. Said portrait hood is an additional lens used when photographing very near objects, such as the screen with titles.

In order to use the said device, it is mounted upon the camera as shown in
85 Fig. 1, the support 4 being folded down upon the main body as shown in Figs. 3 and 4 so that it will offer no obstacle to the taking of the views.

When a title is to be photographed, the
90

[Price 1/-]

taking of views is interrupted, the frame 4 with the screen 5 is raised, Fig. 1, and the title is inscribed upon the said screen. The operator then turns the operating handle of the camera; the number of images formed will depend upon the number of turns of the operating handle.

When the said device is not mounted upon the camera, it may be folded down as shown in Figs. 3 and 4, thus occupying the minimum space, and it may be readily stowed in the sack together with the camera.

Having now particularly described and ascertained the nature of our said invention and in what manner the same is to be performed, we declare that what we claim is:—

1. A device for photographing titles upon a cinematographic film comprising

a flat shelf on which are hinged on one side a collar adapted to be secured to the lens of the cinematographic camera and on the other side a frame wherein is mounted a screen of glass, celluloid or other suitable material, said frame being adapted to be folded down upon said flat shelf so as to be removed from the field of the lens, whereby said shelf may be used as a desk to inscribe on the screen the title to be photographed.

2. A device for photographing titles upon a cinematographic film substantially as described and as shown in the accompanying drawing.

Dated this 26th day of January, 1925.

For the Applicants,

HERBERT HADDAN & Co.,
Chartered Patent Agents,
31 & 32, Bedford Street, Strand,
London, W.C. 2.

Fig. 1

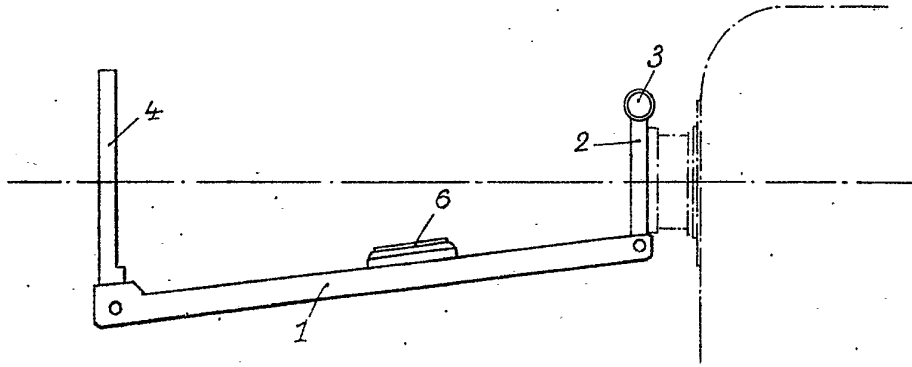

Fig. 2

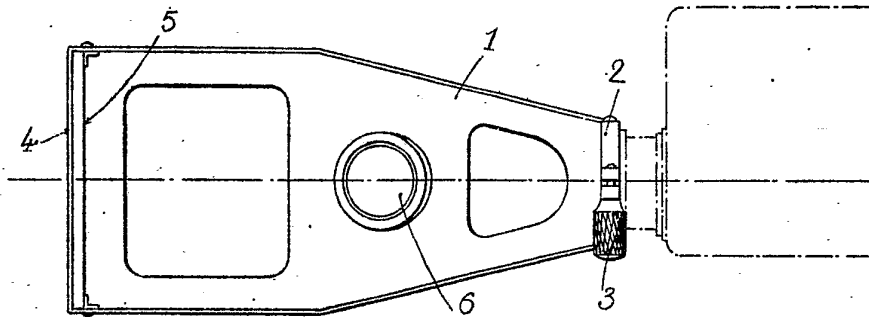

Fig. 3

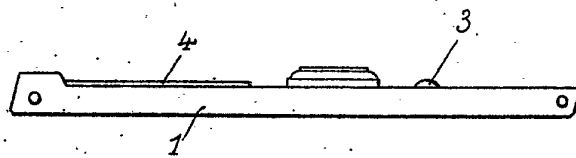
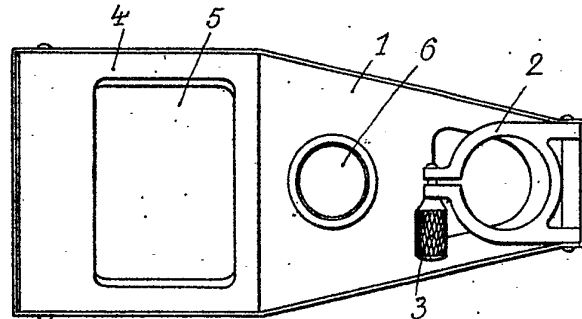

Fig. 4



[This Drawing is a reproduction of the Original on a reduced scale.]